

CARPET KNIFE Generation X Setup Sheet

Modified A-Main TQ and Win

Driver : Hupo Honigel

Race : Las Vegas iic 2008

Date: Aug 2008

Track Type : Fast wide
high bite

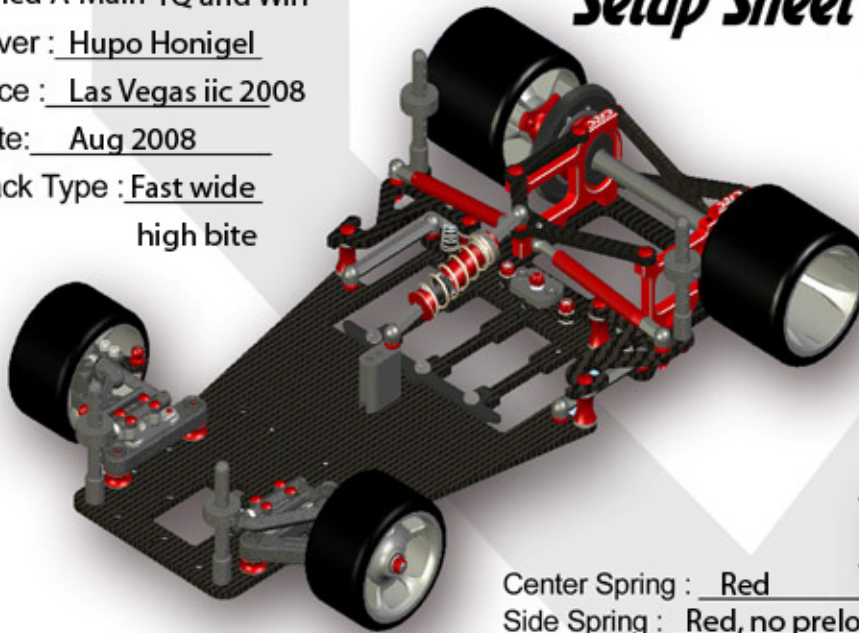

Rear End



Battery Position: Forward

Center Spring : Red
Side Spring : Red, no preload
Damper Tube : 30000
Shock Oil : _____ wt

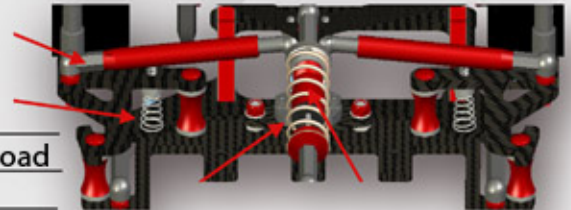

Gilles used the new Encore shock coming soon from CRC

Front End

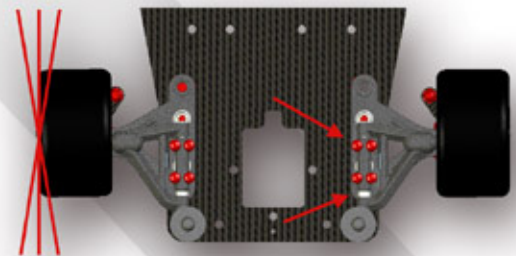
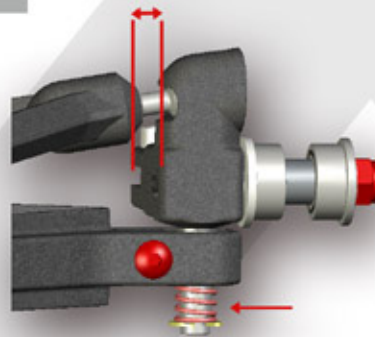
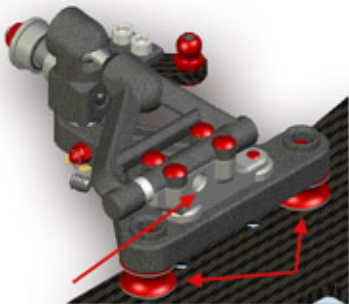

Ride Height Adjuster : long ball upper arm
Caster Block : 5 - dynamic 0
Front Spring : .45mm, little load
Camber : 0.5 mm 0
2 shims each front axle

Caster Shims : 2 front 1 back
Toe Angle : 0 0

Tires - Ride Height - Droop

Front Tire Cmpd Magenta
Tire Size : 1.65
Treatment :: glued both

Ride Height : inner/outer
Front 3.75mm

Rear Pod Droop : 0.5 (but flat at race weight)

Center : 3.5 mm Rear : 4.25 mm

Rear Tire Cmpd : yellow
Tire Size : 1.70
Treatment :: full wash

Other Notes: New CRC exclusive short diff hub with the 3349 Brushless Pod conversion for perfect center motor placement.



CALANDRA RACING CONCEPTS
6785 MARTIN STREET ROME, NY 13440, USA
PHONE & FAX: (315) 338-0867

<http://www.teamcrc.com>
info@teamcrc.com